

Electromagnetic Reflections in Salt Deposits

R. Thierbach

Niedersächsisches Landesamt für Bodenforschung, Hannover

Received December 22, 1973

Abstract. The generation of short high frequency electromagnetic pulses in the VHF-band opens up the possibility of applying electromagnetic reflection methods in the geophysical prospecting of dry formations, with high resolution and also over small distances. A method has been developed using a spark transmitter for locating boundaries in salt deposits. The transmitter, which is technically very simple in contrast to other pulse transmitters, produces short powerful pulses. The results to date show good quality reflections of salt clay and anhydrite.

Key words: Reflection Method (Electromagnetic) – Salt Deposits.

For a long time the boundaries of and discontinuities within salt bodies have been primarily investigated by seismic methods. It was suggested some time ago that high frequency electromagnetic sounding should be applied, because different salt types and the country rock have different electrical properties. Hence, electromagnetic reflections might be expected at the boundaries (Fritsch, 1948; Jung, 1950).

In the meantime a bore hole logging method based on radar has been developed in USA to determine the flanks of salt domes (Holser *et al.*, 1972).

Papers have been read on the application of the electromagnetic reflection method in mines (Nickel *et al.*, 1973; Unterberger 1973).

The first results are described here of a current research program which is being carried out by the Niedersächsisches Landesamt für Bodenforschung and the Bundesanstalt für Bodenforschung for the Forschungsgemeinschaft Seismik e.V.¹. The aim of the program was to develop an electromagnetic reflection method suitable for application in potash and salt mines. Emphasis was placed on simplicity and economy in application.

¹ With subsidies from the Bundesminister für Wirtschaft through the Arbeitsgemeinschaft industrieller Forschungsgemeinschaften AIF and the members from industry of the Forschungsgemeinschaft Seismik e.V.

The technical realization depends mainly on the choice of the frequency range and the working system. The transmitter frequency is chosen according to the required depth of penetration because of the dependency of the attenuation on the frequency of electromagnetic waves in salt. It is also determined by the wanted resolution of the discontinuities of the deposits and, not least, by the dimensions of the antenna. In practice, the frequency should be variable and adaptable to different purposes.

For the investigations being described here, a range of 50–100 MHz was chosen, since for these frequencies the attenuation is tolerable (about 10–20 db/100 m, although both smaller and much greater values are quoted in relevant literature) and the antenna lengths are only about 1 meter.

In principle, both known systems: continuous-wave radar with frequency-modulation and pulse radar can be applied. The pulse radar has the advantage of direct travel-time measurements. The difficulties of generating pulses shorter than 1 μ s in this frequency-range can be avoided by using the cw-fm radar. However, it was found that this method needs much apparatus and time, especially for the necessary broadband antennas. Moreover, this method produces a frequency mash, when several reflecting layers are present. The incoherence inherent in the signal from this method prevents analysis of the signal by simple means.

The generation of pulses by keying a vhf-transmitter, or as proposed in some patents, by very short DC-pulses, which are forced onto the antenna (monocycle radar pulses), seem to be equally cumbersome (Morey *et al.*, 1972).

An as equally simple as effective solution was found using a spark-transmitter, with an antenna coupling different from that of the classical Hertz arrangement. It generates short powerful pulses. This transmitter is made up of a high-voltage low power DC generator and a dipole-antenna with a variable spark gap in the middle. The antenna is connected with the DC-generator by high resistors. The charging procedure of the antenna which depends on the supply voltage, the resistivity and the static antenna capacity C , is uninterrupted as soon as the ignition voltage U_z of the spark gap is reached. During sparking a high frequency oscillation is set off, which is strongly attenuated by the spark-resistance of the electric arc and is therefore of very short duration. This is periodically repeated.

The measured pulse time is about 0.2 μ s. The average pulse output can be estimated from

$$P = k \frac{CU_z^2}{2t}$$

where k is the efficiency of the generator resulting from the heat loss of the spark gap. For values of $k=0.1$; $C=100$ pF; $U_z=2$ kV; $t=0,2$ μ s an average output of 100 W can be found.

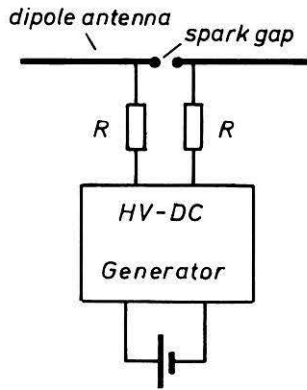

Fig. 1. Schematic circuit diagram of the transmitter

With this configuration, even reflectors more than 200 m away have been located. On the other hand, these short pulses make it also possible to locate reflectors which are less than 20 m away.

The frequency of this apparatus is controlled by the dipole antenna solely. By changing its length the frequency range may be shifted. It is equally simple to suit the emitted pulse output to the required penetration range by changing the sparkover path. The pulse sequence frequency can be altered by changing the feeding potential in such a way that the operator sees a standing wave on the oscilloscope.

The waves are recorded on an oscilloscope with a sufficiently high frequency cut off. It receives the signals from a receiving antenna through an adaptable network and if necessary a broadband amplifier. The frequency characteristic of the receiving antenna influences the signal. A very broadbanded antenna would be ideal. Moreover extended antennae with strong directional characteristics are necessary for spatial location of the reflectors. But as these measurements are often made in narrow adits, limiting the size of antenna, a compromise has to be made.

The transmitter and receiver are battery powered and easily portable. The measurements entail no preparations. The antennae configuration at the salt-wall is, with respect to the electrical coupling, not particularly critical; all measurements are reproducible.

The complete separation of transmitter and receiver makes it possible to operate in much the same way as in seismic investigations. By profiling in 1, 2 or 3 dimensions, travel-time curves can be obtained from which the distance and the position of the reflectors can be calculated.

In contrast to seismics the time-break transference between transmitter and receiver cannot take place without a timelag, because the wave velocities in the cables, the salt and the air are of the same order of magnitude (in

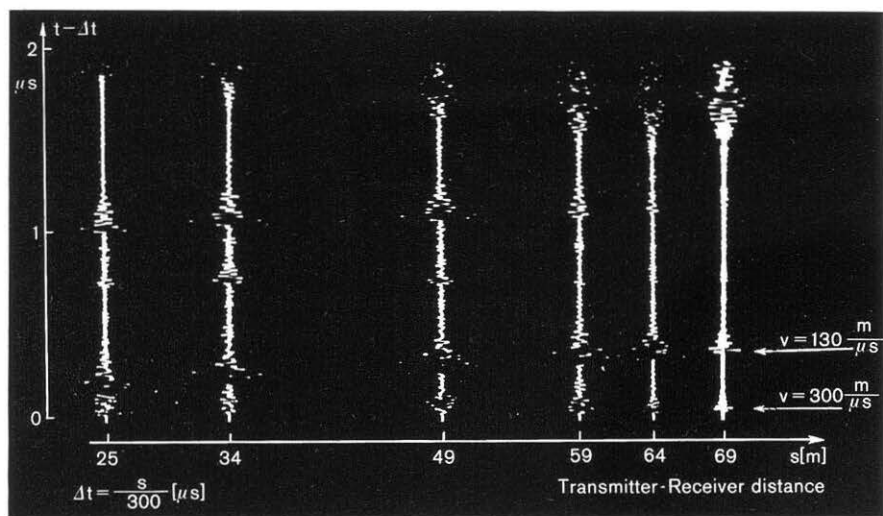

Fig. 2. Record of electromagnetic reflection measurements at different transmitter-receiver distances. On each trace, in sequence, the direct path wave in air and in salt can be seen, followed by several reflections

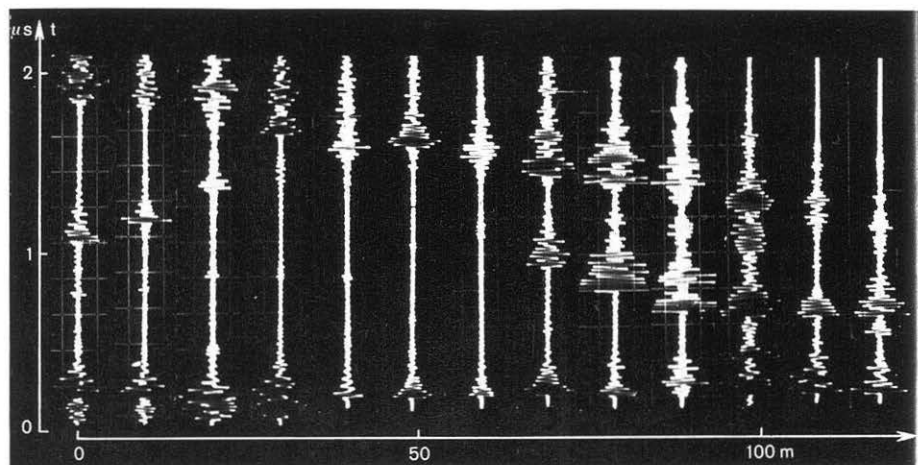

Fig. 3. Electromagnetic reflection measurements in a very disturbed area within a salt dome. Profiling with a constant Transmitter-Receiver spacing of 30 m. Measurements were made every 10 m along the profile (abscissa axis)

salt $v \approx 130$ m/ μ s). It is therefore practical to work with the triggering of the receiver by the direct-beamed electromagnetic wave (delayed representation).

The figures show the schematic circuit diagram of the transmitter (Fig. 1) and registrations from reflection measurements in salt domes (Figs. 2 and 3). The measurements were made in adits within the younger and the older rock-salt formations. The reflections represent the interfaces between rock salt and grey clay or anhydrite.

The author would like to thank H. Mayrhofer for the initiation and stimulation of this research. K. Deppermann† for his support and H. J. Dürbaum and H. Nickel for many fruitful discussions.

References

- Fritsch, V.: Die Ausbreitung hochfrequenter Hertzscher Felder in Kalilagerstätten. *Geofis. Pura Appl.* 12, 23–52, 1948
- Holser, W. T., Brown, R. J. S., Roberts, F. A., Fredriksson, O. A., Unterberger, R. R.: Radar logging of a salt dome. *Geophysics* 37, 889–906, 1972
- Jung, H.: Die Bedeutung der Hochfrequenz für den Bergbau. *Elektrotechnik* 4, 145–148, 1950
- Morey, R. M., Nashua, N. H.: German Patent P 2264037.5, “Geophysikalische Meßeinrichtung”, 1972
- Nickel, H., Thierbach, R., Dürbaum, H. J.: On developments and applications in seismics and high frequency electromagnetics for the solution of some problems in salt mines. Read at 43rd meeting of the SEG, Mexico City, 1973
- Thierbach, R., Mayrhofer, H.: Application for a German Patent P 2360878.5 “Electromagnetisches Reflexionsmeßverfahren zum Orten von stofflichen Diskontinuitäten in Lagerstätten”, 1973
- Unterberger, R. R., Hluchanek, J. A.: Mapping a Salt Dome Top by Electromagnetic Waves from Inside the Salt. Read at 43rd meeting of the SEG, Mexico City, 1973

Dipl.-Ing. R. Thierbach
Niedersächsisches Landesamt
für Bodenforschung
D-3000 Hannover 23
Stilleweg 2
Federal Republic of Germany