

# Archaeomagnetic study of medieval fireplaces at Mannheim-Wallstadt and ovens from Herrenchiemsee (southern Germany) and the problem of magnetic refraction

K. Schurr<sup>1</sup>, H. Becker<sup>2</sup>, and H.C. Soffel<sup>1</sup>

<sup>1</sup> Institut für Allgemeine und Angewandte Geophysik, Universität München, Theresienstr. 41, D-8000 München 2, Federal Republic of Germany

<sup>2</sup> Bayerisches Landesamt für Denkmalpflege, Arabellastrasse, D-8000 München, Federal Republic of Germany

**Abstract.** Ten fireplaces from Mannheim-Wallstadt (MW) and four ovens from Herrenchiemsee (HC) were studied with regard to their archaeomagnetic properties. The ages of the medieval structures were only poorly known and an age dating was intended with the help of the standard curves for the declination and inclination of the geomagnetic field of the past 2000 years, as set up by Thellier (1981) for France. The stability of the NRM was tested with Thellier's test. Of the ten MW fireplaces, only one passed the test, whereas of the four ovens of HC, all passed the test but one of them had to be excluded because of secondary displacements within the structure. The MW fireplace could be dated to 670–700 A.D., in agreement with other archaeological age determinations for the fireplaces. The ovens from HC yielded an age between 1100 and 1170 A.D.

The ovens showed the effect of magnetic refraction. Model calculations carried out on circular ring structures require a susceptibility of the oven material of the order of 0.5 SI units to explain the observed effect. The presently observed mean susceptibility at room temperature is only around  $5 \times 10^{-3}$  SI units. However, heating of the material at 550°C for 2 h in a reducing environment was able to increase the susceptibility by a factor of 20. This effect is explained by the reduction of secondary iron oxides and hydroxides to magnetite. Another increase by a factor of about 1.5 is obtained from the Hopkinson effect (increase of susceptibility with temperature) at the blocking temperature of magnetite. Combining all effects, it is possible to attain values for the susceptibility at the blocking temperature of magnetite as high as 0.2 SI units, which is the order of magnitude required for the explanation of the observed effect of magnetic refraction.

This effect demands that special considerations be made during archaeomagnetic sampling from archaeological ovens or kilns.

**Key words:** Archaeomagnetism – Archaeomagnetic age dating – Magnetic refraction – Susceptibility

## Introduction

The initial purpose of the study was an attempt to date four medieval ovens from Herrenchiemsee and ten fireplaces near Mannheim-Wallstadt (both in southern Ger-

**Table 1.** Geographic coordinates, number *N* of archaeological structures per site and their estimated ages

Locality	(° E)	(° N)	<i>N</i>	Age
Mannheim-Wallstadt (MW)	8.5	49.5	10	First–third century or fifth–seventh century A.D.
Herrenchiemsee (HC)	12.4	47.9	4	Medieval

many) using the archaeomagnetic reference curve for France, published by Thellier (1981) for inclination and declination (Fig. 8). Table 1 shows the geographic coordinates of the sampling localities, the number of sites and their possible ages based on archaeological arguments.

The remnants of the fireplaces from Mannheim-Wallstadt were cast into large blocks of plaster of Paris (about 40 cm thick and wide, 100 cm long) and removed from the ground after orientation with respect to the horizontal plane and geographic north (using a sun compass). Figure 1 shows a sketch map of the position of the fireplaces on the archaeological site.

The ovens from Herrenchiemsee originally had a shape like that shown schematically in Fig. 2. Oriented samples were taken from the floor and from the walls of the structures wherever suitable material was preserved. Figure 3 shows the spatial distribution of the four ovens on the archaeological site as well as the position of the samples within each oven. From the four ovens at Herrenchiemsee, only the ovens HC I, II and IV were in a more or less undisturbed position. The floor of oven HC III showed later internal mechanical movements. Therefore, this material was only used for rock magnetic studies.

## Preparation of specimens

From the huge blocks obtained from the fireplaces at Mannheim-Wallstadt and from the samples from Herrenchiemsee, smaller specimens were cut and embedded in cubes of plaster of Paris with a side length of 6 cm for a convenient measurement with a spinner magnetometer (see next section). Table 2a shows the number of samples and specimens obtained from each of the ten fireplaces at Mannheim-Wallstadt.

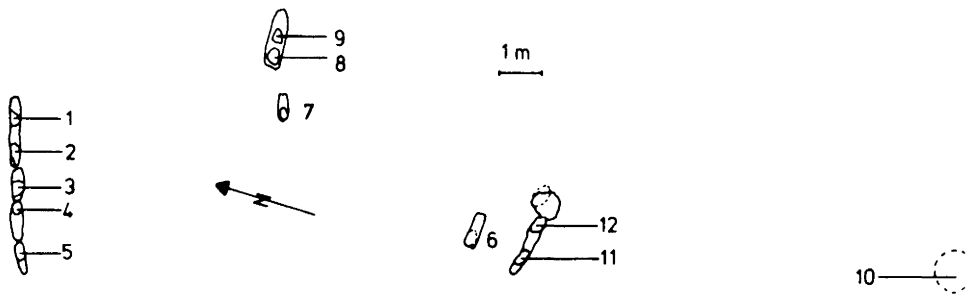

**Fig. 1.** Sketch map of the positions of the fireplaces at Mannheim-Wallstadt. Numbers refer to structure members MW1–MW12 (see also Table 2)

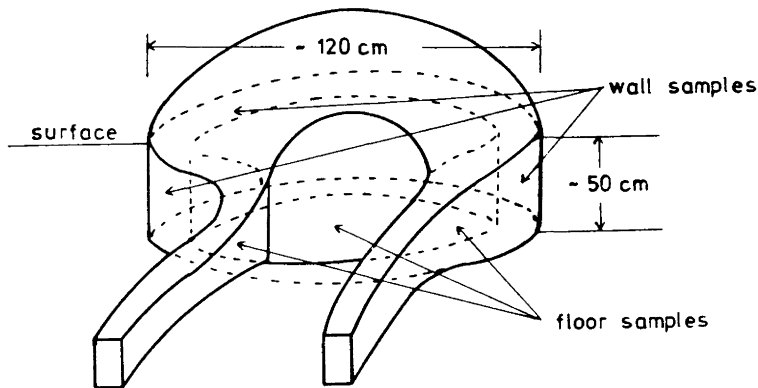

**Fig. 2.** Schematic sketch of the shape and dimensions of the ovens found at Herrenchiemsee

The distribution of the samples and specimens within the ovens at Herrenchiemsee is illustrated in Fig. 3. (Details can also be taken from Table 2b.) It illustrates the position of the samples (in a schematic way) in the wall or the floor of the ovens. The arrow with the full line represents the present magnetic north direction in the sampling area, while the arrow with the dashed line is the archaeonorth direction (see next section). The little arrows marked within the samples are the archaeoremanence directions determined for each specimen. For detail refer to section on magnetic refraction.

#### Archaeomagnetic measurements

The natural remanent magnetization (NRM) of the specimens was measured with a computerized big-sample flux-gate spinner magnetometer. The stability of NRM was checked with the Thellier test (Thellier and Thellier, 1959) by comparing the vertical  $Z$ -components,  $Z_1$  and  $Z_2$ , of the specimens before and after, respectively, a 4-week storage in the geomagnetic field in the reversed position. The viscosity coefficient  $v$  is determined by  $v = \frac{Z_1 - Z_2}{Z_1 + Z_2}$ . Furthermore, the directional shift of NRM was computed for the Thellier test.

Table 3 shows the mean viscosity coefficients  $\bar{v}$  for a selection of specimens of the fireplaces from Mannheim-Wallstadt and the oven specimens from Herrenchiemsee. For the fireplaces at Mannheim-Wallstadt, all viscosity coefficients are greater than 1% with the exception of a large and stable group of specimens from MW 9 with  $\bar{v} = 0.22$ . Similar small  $\bar{v}$  values ( $\bar{v} < 0.5\%$ ) could be found for all ovens at Herrenchiemsee. The NRM of all structures with  $\bar{v} < 0.5$  was taken as the archaeodirection. The results in terms of mean NRM directions and their statistical parameters are summarized in Table 4.

#### Magnetic refraction

In Fig. 3 the directions of the horizontal components of NRM of the individual specimens are shown as small arrows. The horizontal direction of the archaeofield (arrow with dashed line) is the average of the individual directions in the floor specimens. However, there is a systematic deviation of inclination and declination from the mean archaeofield direction in the wall specimens as well as a deviation only of inclination in the floor specimens. These deviations are dependent upon the sample positions (azimuth  $\theta$  and distance  $r$  from the centre) within the structures. Figure 4 shows the variation of the inclination with distance from the centre, for three ovens. In all cases, the inclinations in the centre of the oven floor are significantly lower than in the walls. Effects of the same kind in kilns have already been described by Harold (1960). He interpreted them as a result of the cooling of the kiln and associated mechanical displacements (kiln wall fall-out). Experiments by Weaver (1962) and Aitken and Hawley (1971) indicated, however, that mechanical processes within the cooling kilns could not account for the effects. They discussed magnetic refraction as a possible interpretation.

Magnetic refraction describes the refraction of magnetic field lines at an interface where the magnetic susceptibility  $\chi$  (or permeability  $\mu = \chi + 1$ ) changes sharply. The relation between the angles of the incident field line ( $\alpha_1$ ) and the transmitted field line ( $\alpha_2$ ), and the permeabilities  $\mu_1$  and  $\mu_2$  is:

$$\tan \alpha_1 / \tan \alpha_2 = \mu_1 / \mu_2.$$

The magnetic refraction in a circular ring in vacuum with inner diameter  $a$  and outer diameter  $b$  with permeability  $\mu$  has been described by Jackson (1975). A modification of the formulae with special application to the shape of the ovens can be taken from Schurr (1983). The alignment

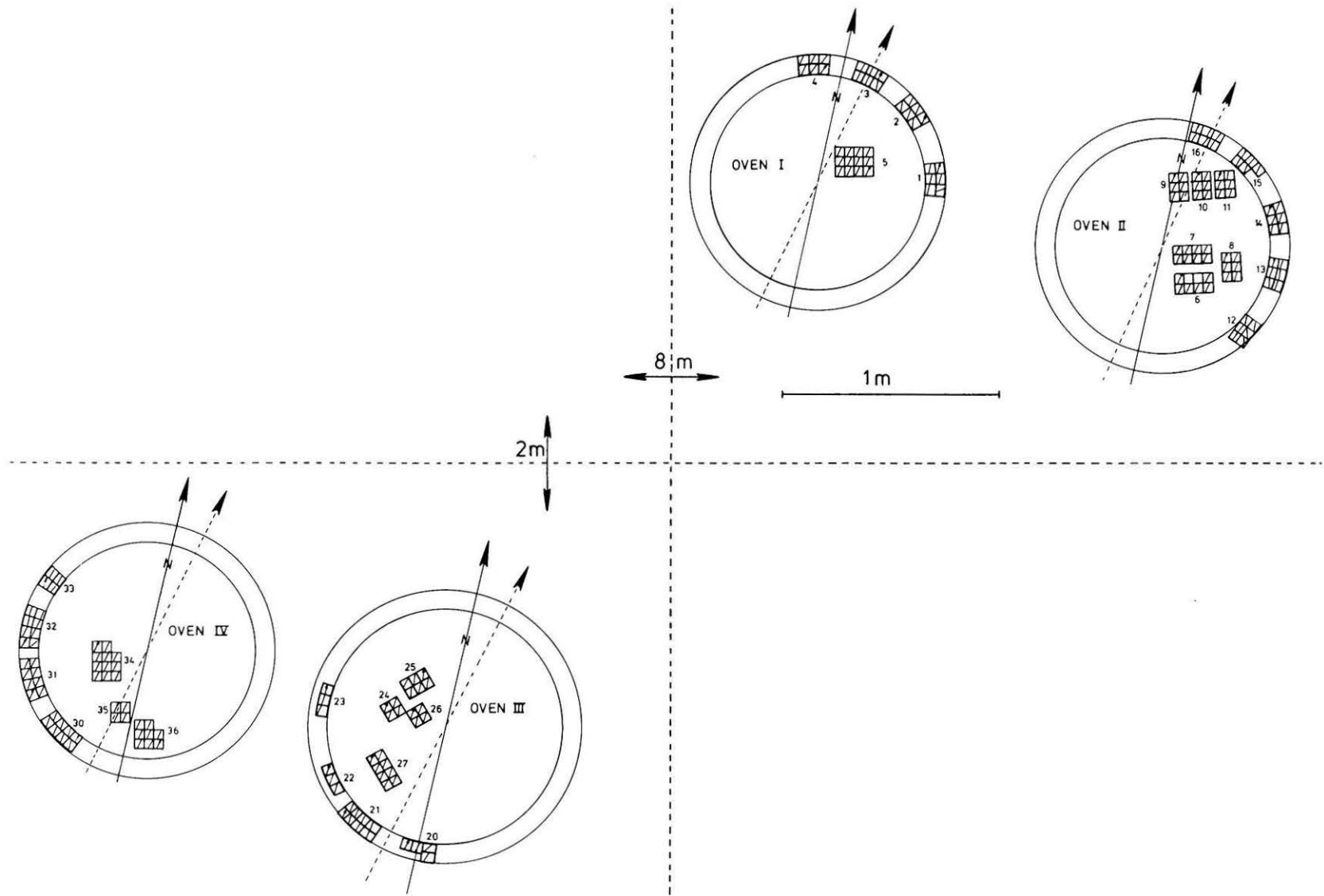

**Fig. 3.** Sketch map of the positions of the four ovens at Herrenchiemsee and distribution of the samples in the four ovens. The outer ring represents the oven wall, the inner area the oven floor. *Large arrows*: with *full line*: present orientation of the magnetic meridian; with *dashed line*: archaeo-orientation of the magnetic meridian. *Small arrows* and *thin lines* within each specimen: direction of the horizontal component of the stable natural remanence

**Table 2.** Number  $N$  of samples and number  $n$  of specimens obtained from each archaeological structure

a	Locality	Structure	$N$	$n$		
	Mannheim-Wallstadt	MW1	18	36		
		MW3	6	6		
		MW4	6	6		
		MW5	6	12		
		MW6	11	11		
		MW7	18	18		
		MW9	23	23		
		MW10	9	9		
		MW11	12	19		
		MW12	12	12		
		b	Locality	Structure	$N$	$n$
			Herrenchiemsee	HC I, floor	1	12
HC I, wall	4			24		
HC II, floor	6			38		
HC II, wall	5			29		
HC III, floor	4			22		
HC III, wall	4			18		
HC IV, floor	3			23		
HC IV, wall	4			28		

**Table 3.** Mean viscosity coefficients  $\bar{v}$ , in percent, of the fireplaces at Mannheim-Wallstadt and the ovens at Herrenchiemsee.  $n$  = number of specimen

Structure	$n$	$\bar{v}$	Remarks
MW1	36	8.96	
MW2	6	37.98	
MW4	6	1.78	
MW5	12	40.96	
MW6	11	12.77	
MW7	18	9.53	
MW9	23	2.89	All
	4	15.58	Very viscous group
	19	0.22	Stable group
MW10	9	4.55	
MW11	19	41.51	
MW12	12	5.09	
HC I, floor	12	0.38	
HC I, wall	24	0.27	
HC II, floor	8	0.26	
HC II, wall	8	0.38	
HC III, floor	8	0.27	
HC III, wall	8	0.42	
HC IV, floor	8	0.28	
HC IV, wall	8	0.38	

of the field lines within the circular ring is similar to that of Fig. 5 and has a distribution with the azimuth  $\theta$  as shown in Fig. 6. The effect depends mainly on the susceptibility of the circular ring and, to some extent, also on the geometry of the ring. The curves shown in Fig. 6 have been computed for values of the radius of 57.5 cm (curves 2 and 4) and 62.5 cm (curves 1 and 3), with values for the susceptibility of 0.5 and 0.1 SI units, respectively.

The actually observed variations of the declination from the mean archaeodirection, dependent on the azimuthal positions of the specimens in the oven walls, have also been plotted in Fig. 6. Despite a considerable scatter of the exper-

**Table 4.** Mean stable NRM directions of the archaeological structures, subdivided into floor and wall specimens

Structure	$I$ (°)	$D$ (°E)	$N$	$\alpha_{95}$ (°)	Standard deviations		$k$
					$I$ (°)	$D$ (°)	
MW9	71.04	356.53	18	0.83	0.28	1.12	1,700
HC I, floor	57.92	13.85	12	1.58	0.81	0.49	750
HC I, wall	65.42	10.68	24	1.71	0.89	2.56	310
HC II, floor	59.88	11.08	38	0.78	0.32	0.50	880
HC II, wall	63.08	9.55	29	2.53	1.34	3.18	110
HC III, floor	63.38	2.79	22	1.22	0.39	1.25	720
HC III, wall	65.76	10.69	18	1.12	0.38	1.15	1,100
HC IV, floor	54.12	15.29	23	1.43	0.75	0.44	450
HC IV, wall	59.81	14.24	28	1.60	0.56	1.35	290

$I$ : inclination;  $D$ : declination;  $N$ : number of specimens;  $\alpha_{95}$  radius of cone of confidence;  $k$ : precision parameter

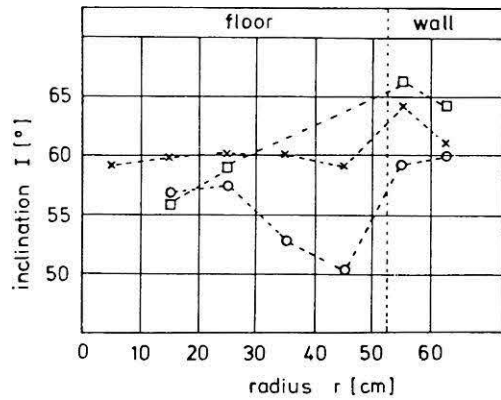
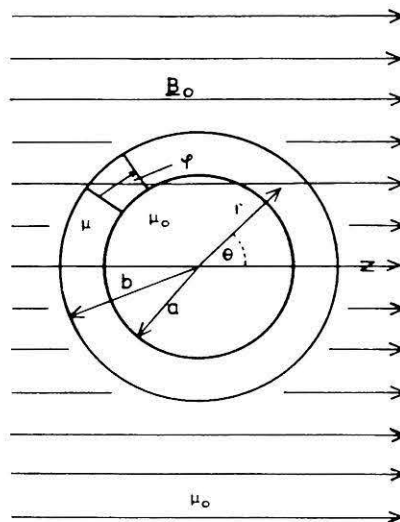
**Fig. 4.** Variation of the mean inclination of floor and wall specimens with distance  $r$  from the centre, for three ovens. The inclination of the wall specimens is significantly higher than that of floor specimens**Fig. 5.** Alignment of the field lines within a circular ring of permeability  $\mu$  situated in vacuum (permeability  $\mu_0$ ).  $r$ : radius of the ring.  $\theta$ : azimuth of a volume element of the ring.  $\varphi$ : angle between the field direction in the volume element and the external homogeneous field. (Modified from Bergmann-Schaefer, 1974)

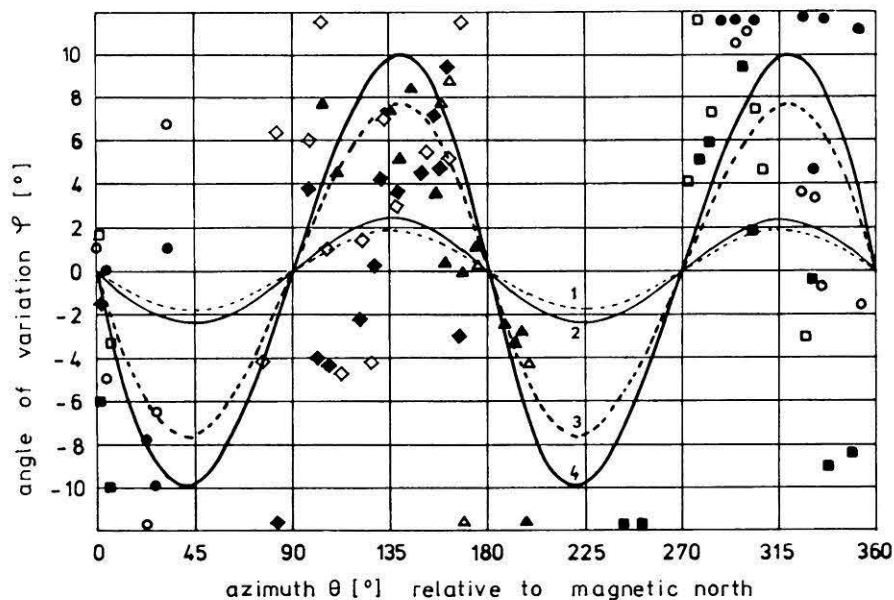

Fig. 6. Variation of the orientation  $\varphi$  of the field lines within a circular ring of radius  $r$  and susceptibility  $\chi$  with azimuth  $\theta$ . For definition of  $\varphi$ ,  $r$  and  $\theta$ , see legend of Fig. 5. The sine curves are computed for the following parameters: 1;  $r=62.5$  cm and  $\chi=0.1$  SI units. 2;  $r=57.5$  cm and  $\chi=0.1$  SI units. 3;  $r=62.5$  cm and  $\chi=0.5$  SI units. 4;  $r=57.5$  cm and  $\chi=0.5$  SI units. The open symbols refer to  $r=57.5$  cm, the closed symbols refer to  $r=62.5$  cm. Circles: HC I; squares: HC II; triangles: HC III; diamonds: HC IV

imental data, it can be seen that the data follow, in general, the predicted azimuthal distribution. Unfortunately, the state of conservation of the ovens did not allow sampling of all azimuthal positions of all ovens.

#### Rock magnetic studies

As seen from Fig. 6, a susceptibility of the order of 0.5 SI units of the oven material is required to explain the observed effects. The carriers of remanence of baked earths have been studied in detail by Le Borgne (1955, 1960a, 1960b, 1965) Mullins (1974) and Graham and Scollar (1976). X-ray powder studies were only possible for the material of the fireplaces at Mannheim-Wallstadt. Here, enough ore grains could be extracted with a hand magnet. Measurements on material from seven fireplaces gave a mean cubic lattice constant of  $8.376 \text{ \AA}$  ( $\pm 0.019$ ) indicating that the extracted magnetic phase is mainly magnetite with, however, some modifications towards maghemite (Rumble 1976). Unfortunately, the magnetic phases of the oven material was too fine-grained for extraction.

The Curie temperatures could be determined for the MW samples as well as for HC samples (for abbreviations see Table 1). They are around  $T_c=580\text{--}590$  °C, which is higher than  $T_c$  for pure magnetite (580 °C) and also indicates some degree of maghemitization.

The susceptibility of specimens from HC I, II and IV was measured with a 1 kHz bridge. The mean value for 12 specimens was  $4.8 \times 10^{-3}$  SI units, with maximum values as high as  $1.4 \times 10^{-2}$ . The anisotropy of susceptibility was also measured. Aitken et al. (1981) showed that the anisotropy of susceptibility, which is indicative of an alignment of the magnetic minerals, may affect archaeomagnetic data. However, we only found anisotropies of the order of less than 2.5%.

These mean susceptibility values are of course not sufficient to explain the observed effects of magnetic refraction as illustrated in Fig. 6. However, it should be considered that the thermoremanent magnetization was formed in the oven walls and floors under special conditions. Firstly, it was certainly formed at high temperatures, not much below

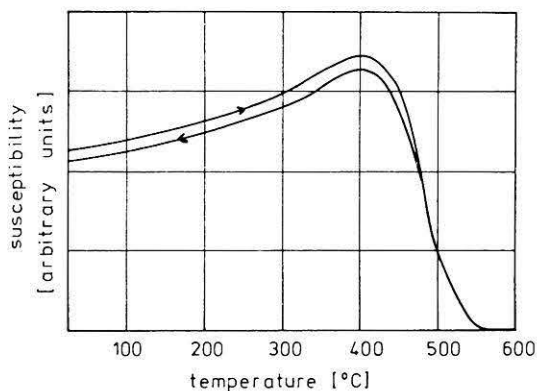

Fig. 7. Hopkinson effect showing the increase of susceptibility with temperature, with a maximum below the Curie temperature. Susceptibility given in arbitrary units

the Curie temperature of magnetite. This implies that the susceptibility of the material at the blocking temperature of the magnetite should be considered rather than that measured at room temperature. Secondly, during firing, there was a reducing atmosphere within the oven which probably favoured the formation of magnetite from most of the iron present in the kiln material. Maghemite may have formed later on, during cooling in an oxidizing environment. Weathering of the entire structure in the soil may also have caused the formation of iron hydroxides like Goethite.

We therefore measured the susceptibility of oven wall and oven floor material as a function of temperature. Figure 7 shows such a measurement, which indeed showed an increase at elevated temperatures (Hopkinson-effect), but the enhancement was not larger than a factor of 1.5.

Mullins (1974) and Graham and Scollar (1976) showed that the susceptibility of archaeological material could be increased considerably by heating the material in a reducing atmosphere together with organic matter. We did similar experiments by mixing powdered material from MW as well as HC with wheat flour (5% by weight) and heating in a nitrogen atmosphere for 2 h at 550 °C. The results are summarized in Table 5. They show that in some cases the

**Table 5.** Enhancement of natural susceptibility  $\chi_o$  by heating of oven and fireplace materials for 2 h at 550° C in a reducing environment ( $\chi_h$ ). For experimental details see text.  $\chi_o$  and  $\chi_h$  are given in  $10^{-3}$  SI-units

Sample	$\chi_o$	$\chi_h$	$\chi_h/\chi_o$
MW 15/6+	1.60	20.30	15.8
MW 2/4			
MW 15/12	5.80	13.30	2.3
HC III, wall	0.60	11.50	19.2
HC I, wall	0.83	15.90	19.2
HC II, wall	3.25	15.20	4.7
HC IV, wall	1.55	13.70	8.8

susceptibility could be enhanced by a factor of almost 20, while in some cases only a small increase by a factor of 2 could be obtained. The enhancements are especially large in those cases where the initial natural susceptibility  $\chi_o$  was very low ( $<3 \times 10^{-3}$  SI units). The low values of  $\chi_o$  may have been caused by iron hydroxides and hematite as the

most abundant iron-containing minerals, while in the cases with high  $\chi_o$  values magnetite may already have been present in the natural samples. The reduction of the material may be responsible for an enhancement of  $\chi$  by as much as a factor of 20. This could enhance the measured mean susceptibility of  $5 \times 10^{-3}$  SI units up to about 0.1 SI units.

The total amount of iron present in the material (assuming that it is all transformed into magnetite in a reducing environment) should determine an upper limit for the susceptibility of the material. The total iron content was determined for four representative specimens by wet chemical analysis. A surprisingly uniform iron content was obtained, from which a  $\text{Fe}_3\text{O}_4$  content of  $(2.43 \pm 0.03)\%$  was calculated. With an initial mass susceptibility  $\chi_{\text{gr}}$  of magnetite of  $2.5 \times 10^{-3}$  SI units (Landolt-Börnstein 1970) and the observed density of  $2 \text{ g/cm}^3$  for the material, we obtained a value of 0.12 SI units as an upper limit for the volume susceptibility  $\chi_v$  at room temperature. Due to the Hopkinson effect, the volume susceptibility near the blocking temperature will be of the order of 0.2 SI units. This is the required range to cause the observed variation of declination in most of the wall samples from Herrenchiemsee.

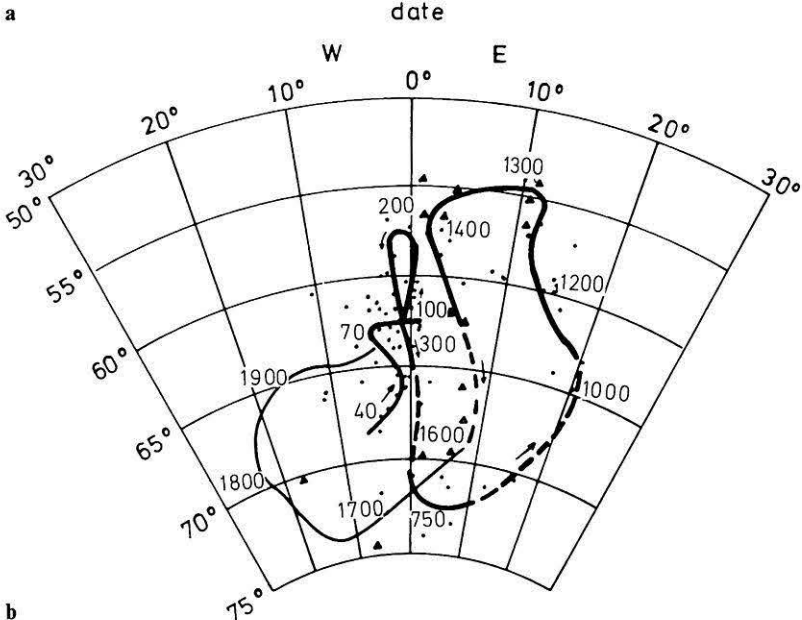
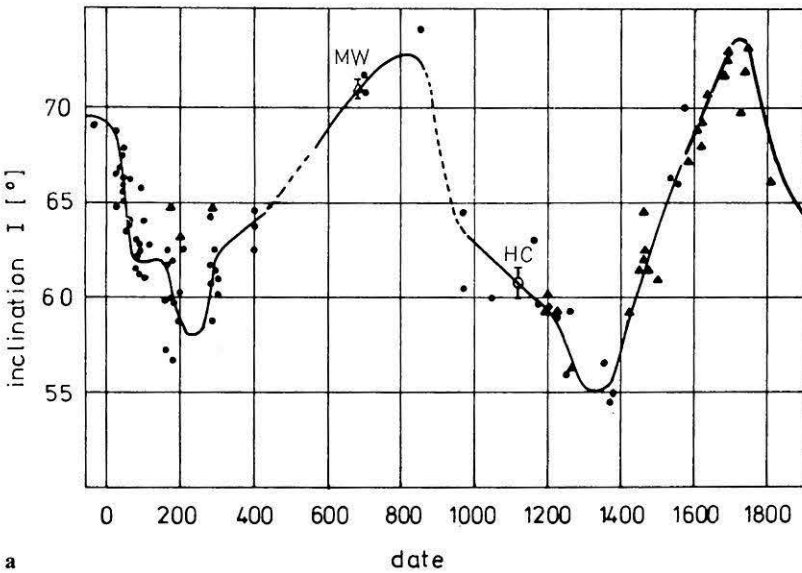

**Fig. 8a and b.** Standard curves for the archaeosecular variation in France compiled by Thellier (1981) for the last 2000 years. The values for the declination and inclination have been reduced to the geographical coordinates at Paris. **a** Inclination. *Heavy full line* from 1550 A.D. to present: direct measurements in Paris. *Dots*: data from archaeological structures. *Triangles*: data from bricks and tiles. *Full line*: reliable parts of the curve. *Dashed lines*: uncertain parts. *Open circle*: mean inclination value for the three ovens at Herrenchiemsee. *Open triangle*: mean inclination value for the fireplace MW 9 from Mannheim-Wallstadt. Error bars are also shown. **b** Declination and inclination, combined. Numbers are years A.D. *Thin curve* from 1600 A.D. to present: direct measurements in Paris. *Heavy lines*: interpolated curve from reliable archaeomagnetic data. *Dashed heavy lines*: uncertain parts of the curve



## Age of the archaeological structures

The updated standard curves for the variation of  $I$  and  $D$  have been published by Thellier (1981) and they are shown in Fig. 8. For the age determination, the mean of all specimens (walls and floors) was calculated for three of the four kilns at Herrenchiessee and for the fireplace number 9 at Mannheim-Wallstadt. The data are summarized in Table 6 together with the statistical parameters.

Thellier did not accept that kilns show any systematic pattern of distortion (Thellier 1981). However, he always averaged the results of as many specimens as possible from widely spaced places within one archaeological structure and so minimized the effect of magnetic refraction. Therefore, a separate discussion of the directions of remanence of floor and wall samples was not regarded as appropriate, at present, for the archaeomagnetic age dating using Thellier's standard curves.

Although the standard curves have been reduced to the geographic coordinates of Paris, they can also be used for southern Germany with the application of a dipole correction, at least for the inclination values. However, the corrections are so small ( $<1^\circ$ ) that they have been neglected. From the present dipole field, the differences in declination are of the order of  $2^\circ$  and have probably not been very much larger in the past 2000 years.

For the fireplace MW 9, with an inclination of  $71^\circ$ , there are several possible age intervals on the standard curve (Fig. 8a). The ages around 1,700 A.D. must be excluded because of the general archaeological situation. The observed declination value of  $356.5^\circ$  (see Fig. 8b) and the inclination ( $71^\circ$ ) make an age of between 670 and 700 A.D. for the last firing most likely, and not the other possible ages of around 50 B.C. (from an extrapolation of the curve of the inclination to earlier dates) or 900 A.D. The age of 670–700 A.D. is also likely from the archaeological dating of the entire group of fireplaces at Mannheim-Wallstadt by other methods, yielding ages of the fifth to the seventh century A.D. Reference structure nearest in direction: Thellier (1981) Table IV, No. 125: Huy (oven 2), age: approx. 700 A.D.

The remanence directions determined for the three ovens gave values for  $I$  between  $57^\circ$  and  $63^\circ$ , and values for  $D$  between  $12^\circ$  and  $15^\circ$  E. From the standard curves of Fig. 8, only the age interval between 950 and 1,250 A.D. is in agreement with the observed data set. Other age intervals, which could be possible from the inclination values alone (1,400–1,500 A.D. or 50–400 A.D.) can be excluded; the later alternative because of archaeological reasons, the earlier one because of the declination values.

The archaeological situation of the ovens at Herrenchiessee makes it likely that all were in use almost simultaneously, that is to say at least within one generation, and not over a time span of almost 300 years which we obtain if we use the determined mean remanence direction of each oven. For this reason we used the mean remanence direction of all three ovens ( $I=60.6^\circ$  and  $D=13.8^\circ$  E) for the archaeomagnetic age dating.

From the averaged standard curve of the inclination (Fig. 8a) we determine the interval between 1,100 and 1,170 A.D. as the probable time span for the last firing of the three ovens at Herrenchiessee. Reference structure nearest in direction: Thellier (1981) Table IV, No. 163: Plo-meur St. Saturnin, age:  $1,050 \pm 90$  A.D.

**Table 6.** Mean stable NRM directions. For details see also legend of Table 4

Structure	$I$ ( $^\circ$ )	$D$ ( $^\circ$ E)	$N$	$\alpha_{95}$ ( $^\circ$ )	$k$	Standard deviations	
						$I$ ( $^\circ$ )	$D$ ( $^\circ$ )
MW 9	71.04	356.53	18	0.83	1,700	0.28	1.12
HC I	63.43	12.30	36	1.92	160	0.90	1.70
HC II	61.26	10.59	67	1.21	210	0.49	1.04
HC IV	57.24	14.67	51	1.28	240	0.60	0.76
HC (all)	60.63	13.81	154	1.24	84	0.57	1.10

## Discussion and conclusion

The observed effect of magnetic refraction seems to be a serious problem for the evaluation of the secular variation of the geomagnetic field by archaeomagnetic measurements and the setting up of standard curves for archaeomagnetic dating. Thellier (1981), and also in earlier papers, tried to avoid this by collecting as many specimens as possible from the archaeological sites hoping that the effects would be averaged out. As a general rule, one can say that the declination values are least affected in specimens taken from the centre of the floor of kilns or from places with azimuth angles  $0^\circ$ ,  $90^\circ$ ,  $180^\circ$  and  $270^\circ$  with respect to the magnetic meridian of circular structures. (For definition of the azimuth see Figs. 5 and 6.) The inclination values are most disturbed (too shallow) in the floor specimens. They are also disturbed in wall specimens (too steep) at azimuth positions  $0^\circ$  and  $180^\circ$  and are probably undisturbed in azimuth positions  $90^\circ$  and  $270^\circ$ . In poorly preserved structures it is often possible to take samples in only a few places. If they are not adequately placed over the entire structure, both  $D$  and  $I$  values can be biased in an unknown way. So far there are no possibilities of making proper corrections. As shown earlier the corrections depend not only on the geometry of the archaeological structures, but also on the rock magnetic properties of the material at the blocking temperature when the TRM was acquired. Further rock magnetic studies are planned with the aim of providing means to correct archaeomagnetic data for the effects of magnetic refraction.

*Acknowledgements.* The measurements were made in the Institute für Allgemeine und Angewandte Geophysik, University of Munich. We thank Professor Angenheister for his support. The financial support of the Deutsche Forschungsgemeinschaft and the Stiftung Volkswagenwerk is gratefully acknowledged.

## References

- Aitken, M.J., Alcock, P.A., Bussell, G.D., Shaw, C.J.: Archaeomagnetic determination of the past geomagnetic intensity using ancient ceramics: allowance for anisotropy. *Archaeometry* **23**, 53–64, 1981
- Aitken, M.J., Hawley, H.N.: Archaeomagnetism: Evidence for magnetic refraction in kiln structures. *Archaeometry* **13**, 83–85, 1971
- Bergmann, L., Schaefer, C.: *Lehrbuch der Experimentalphysik II*, W. de Gruyter, Berlin, 1974
- Graham, I.D.G., Scollar, I.: Limitation on magnetic prospection in archaeology imposed by soil properties. *Archaeo-Physica* **6**, 1–126, 1976

- Harold, M.R.: Magnetic dating: kiln wall fall-out. *Archaeometry* **3**, 47–49, 1960
- Jackson, I.D.: *Classical electrodynamics*. J. Wiley and Sons, London, 1975
- Landolt-Börnstein: *Zahlenwerte und Funktionen aus Naturwissenschaften und Technik*, Vol. III, 4b, 1970
- Le Borgne, E.: Susceptibilité magnétique anormale du sol superficiel. *Ann. Géophys.* **11**, 399–419, 1955
- Le Borgne, E.: Influence du feu sur les propriétés magnétiques de sol et sur celles du schiste et du granite. *Ann. Géophys.* **16**, 159–196, 1960a
- Le Borgne, E.: Etude expérimentale du trainage magnétique dans le cas d'un ensemble de grains magnétiques très fins dispersés dans une substance non magnétique. *Ann. Géophys.* **16**, 445–503, 1960b
- Le Borgne, E.: Les propriétés magnétiques du sol. Application à la prospection des sites archéologiques. *Archaeo-Physica I*, Beihefte der Bonner Jahrbücher **15**, 1–20, 1965
- Mullins, C.E.: The magnetic properties of soil and their application to archaeological prospection. *Archaeo-Physica* **5**, 143–348, 1974
- Rumble, D. (ed): *Reviews in Mineralogy*, Vol. 3: Oxide Minerals. Min. Soc. of America, Short Course Notes, Southern Printing Comp., Blacksburg, Virginia, USA, 1976
- Schurr, K.: *Archäomagnetische Untersuchungen an Feuerstellen aus Mannheim-Wallstadt und Öfen aus Herrenchiemsee*. Unpubl. Thesis, Universität München, 1983
- Thellier, E., Thellier, O.: Sur l'intensité du champ magnétique terrestre dans le passé historique et géologique. *Ann. Géophys.* **15**, 285–376, 1959
- Thellier, E.: Sur la direction du champ magnétique terrestre, en France, durant les deux derniers millénaires. *Phys. Earth Planet. Inter.* **24**, 89–132, 1981
- Weaver, G.H.: Archaeomagnetic measurements on the Second Boston Experimental Kiln. *Archaeometry* **5**, 93–104, 1962

Received February 10, 1984; Revised June 1, 1984

Accepted June 15, 1984